

AVERY DENNISON MARKETING SPECIFICATION

HISTORY

THE SUBJECT MATTER DISCLOSED HEREIN EMBODIES PROPRIETARY INFORMATION WHICH IS THE CONFIDENTIAL PROPERTY OF THE AVERY DENNISON CO. NONE OF WHICH SHALL BE COPIED, REPRODUCED, DISCLOSED TO OTHERS, PUBLISHED OR USED IN WHOLE OR IN PART, FOR ANY PURPOSE OTHER THAN THAT FOR WHICH IT IS BEING MADE AVAILABLE WITHOUT THE EXPRESS ADVANCE WRITTEN PERMISSION OF A DULY AUTHORIZED AGENT OF THE COMPANY. THIS DOCUMENT IS THE PROPERTY OF THE AVERY DENNISON CO. AND IS TO BE RETURNED TO THE COMPANY ON DEMAND.

REV.	DATE	DESCRIPTION
H	01.21.13	UPDATED TO THE NEW FORMAT; UPDATED GEOMETRY TO MATCH PART
I	03.15.13	UPDATED BALLOON 5
J	1-22-15	ADDED MIN INSTALL TEMP: UL LOGO AND 5000 PER CASE CHG LOOP TENSILE TO NEWTONS

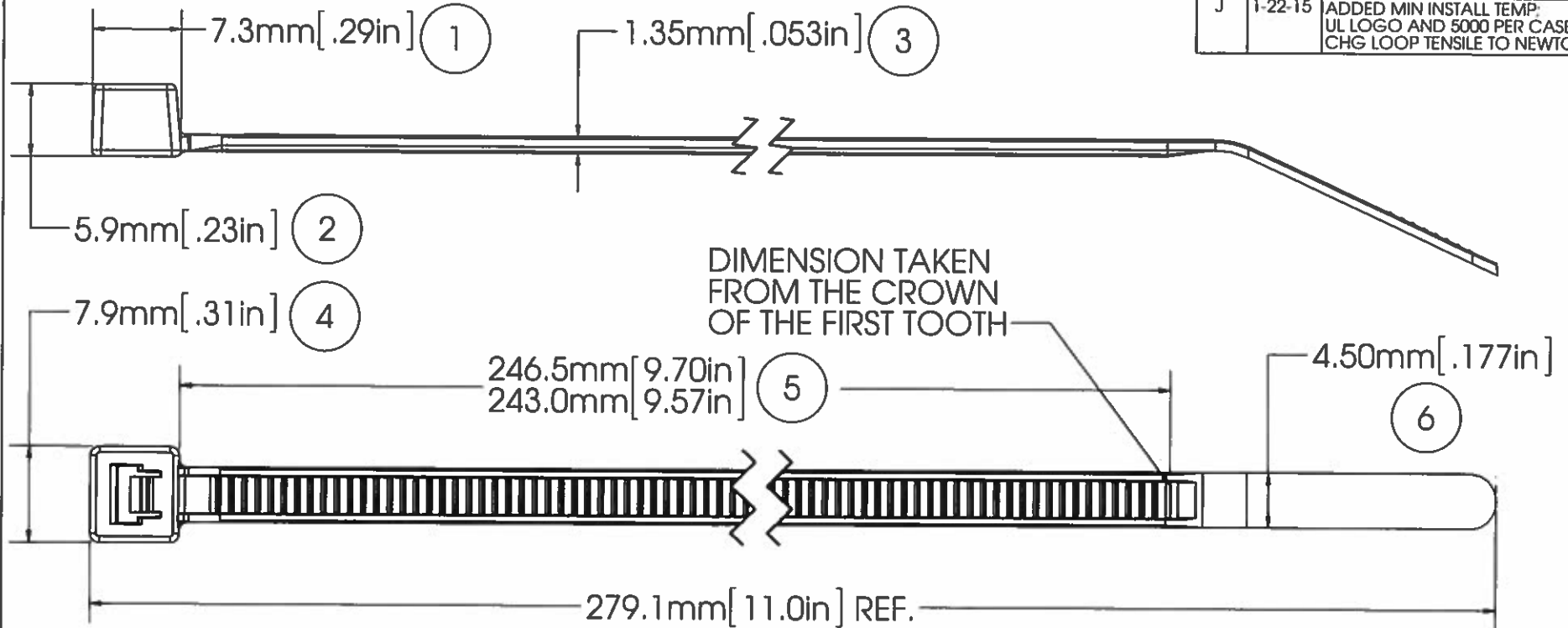

NOTE: THESE CABLE TIES ARE PLENUM RATED AND HAVE A FLAMMABILITY RATING OF V-2



LOOP TENSILE STRENGTH: 50 LBF / 220N MIN. PER AS-23190	APPROVALS:	ENG. APPR. <i>[Signature]</i> 1/22/15	AVERY DENNISON <small>FASTENER DIVISION FITCHBURG, MA 01420 U.S.A. TEL. 1-800-225-5913 FAX. 978-353-8157</small>
OPERATING TEMP: -40°F (-40°C) TO 220°F (105°C)		Q.A. APPR. <i>[Signature]</i> 1/22/15	
MIN. INSTALLATION TEMP.: 32°F(0°C)	SPECIFIED TOLERANCES ARE:	MATERIAL	DESCRIPTION 11" CABLE TIE, STD
WEIGHT: 0.061 OZ./1.80 GRAMS		.XX ± .03 IN. .X ± .7 MM	
BUNDLE DIAMETER: 1.59mm - 76.2mm	.XXX ± .010 IN. .XX ± .25 MM	COLOR	STOCK NO. 08056-0
TOOL: 12001 - HAND INSTALLATION TOOL 12500 - PNUEM. INSTALLATION TOOL	ANGULAR: ± 2°	BLACK	REV. J
TOOL TENSION SETTING: 6 - 8			
PACKAGING: 1000/BAG 5000/CASE			

5

4

3

2

1